

CR C
TROUGH PUMP
SYSTEMS

TPS50™

Product Manual

PATENT PENDING; PCT NO. WO2019056049A1



The solar pump is powered by a solar panel. In order to make the pump work by solar energy, the solar panel needs to be placed in the sunlight with its solar cells facing the sun as much as possible.

The performance of the pump depends on sunlight intensity and the incident angle at which sunlight strikes the panel surface.

The latest DC brushless motor technology is introduced in the pump design and manufacturing, so that the pump has higher efficiency and a longer service life.

Ideally, set up the solar panel facing north at 45 degrees to the horizontal. (Facing South if in Northern Hemisphere)

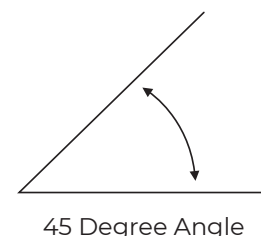

COMPONENTS

Figures showing TPS50 components and assembly.

SPECIFICATIONS FOR TPS50 TROUGH PUMPING SYSTEM

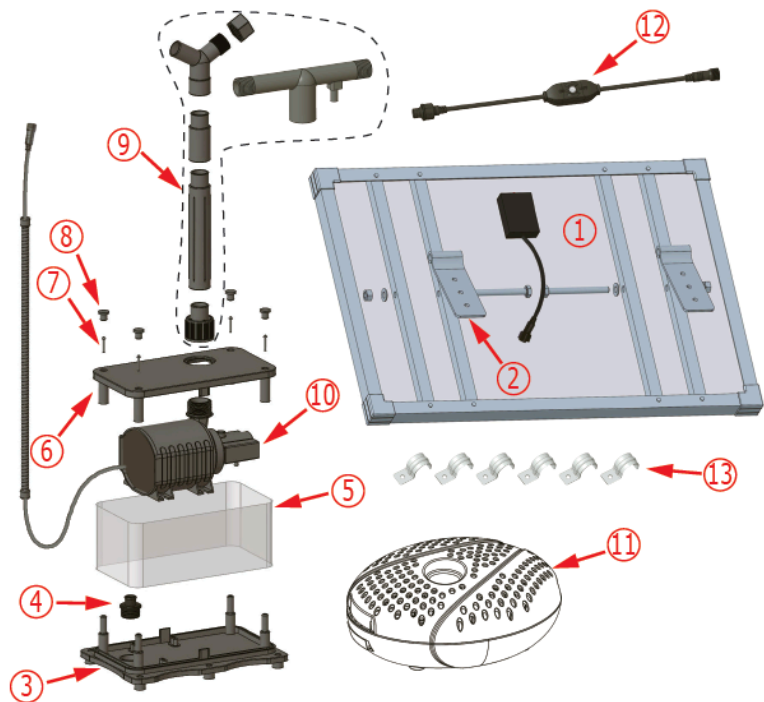

TPS50 Assembly

- 1,TPS50-SP Solar Panel
- 2,TPS50-HK Hinge Kit x2
- 3,TPS50-FB Filter Base
- 4,TPS50-CG Cable Grommet
- 5,TPS50-FS Filter Screen
- 6,TPS50-FT Filter Top
- 7,TPS50-SS Screws x4
- 8,TPS50-SPP Screw Protection Plug x4
- 9,TPS50-TK T Nozzle & Tube Kit
- 10,TPS50-PM Pump and Magnet
- 11,TPS50-FC Filter Case
- 12,TPS50-OOS ON/OFF Switch
- 13,TPS20-CS Cable Saddle

ITEM NO.	TPS50	
DESCRIPTION	Trough Pumping System	
WARRANTY	12 Months	
SOLAR PANEL	PEAK POWER	50W
	MAX-POWER VOLTAGE	17.28V
	MAX-POWER CURRENT	2.894A
PUMP	PUMP ITEM	TPS50-PM
	MAX. HEAD	3m (9.86ft)
	MAX. FLOW RATE	3400LPH (898.1GPH)
	CABLE LENGTH	3m (9.8ft)
	NOZZLE ITEM	TPS50-TK
FLOW ADJUSTABLE	NO	
DRY RUN PROTECTION	NO	

COMPONENTS

Figures showing TPS50 components and assembly.

TPS50 MOTOR PARTS LIST

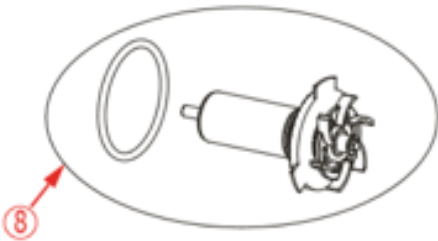
	<table border="0"> <tr> <td style="padding-right: 10px;">1,TPS50-MH</td> <td>Motor Housing</td> </tr> <tr> <td>2,TPS50-OR</td> <td>O Ring Seal</td> </tr> <tr> <td>3,TPS50-PR</td> <td>Pump Rotor</td> </tr> <tr> <td>4,TPS50-PD</td> <td>Pump Difuser</td> </tr> <tr> <td>5,TPS50-PI</td> <td>Pump Impellor</td> </tr> <tr> <td>6,TPS50-RC</td> <td>Rotor Circlip</td> </tr> <tr> <td>7,TPS50-IHM</td> <td>Impellor Housing & Magnet</td> </tr> <tr> <td>8,TPS50-RK</td> <td>Repair Kit(2,3,4,5,6)</td> </tr> </table>	1,TPS50-MH	Motor Housing	2,TPS50-OR	O Ring Seal	3,TPS50-PR	Pump Rotor	4,TPS50-PD	Pump Difuser	5,TPS50-PI	Pump Impellor	6,TPS50-RC	Rotor Circlip	7,TPS50-IHM	Impellor Housing & Magnet	8,TPS50-RK	Repair Kit(2,3,4,5,6)
1,TPS50-MH	Motor Housing																
2,TPS50-OR	O Ring Seal																
3,TPS50-PR	Pump Rotor																
4,TPS50-PD	Pump Difuser																
5,TPS50-PI	Pump Impellor																
6,TPS50-RC	Rotor Circlip																
7,TPS50-IHM	Impellor Housing & Magnet																
8,TPS50-RK	Repair Kit(2,3,4,5,6)																

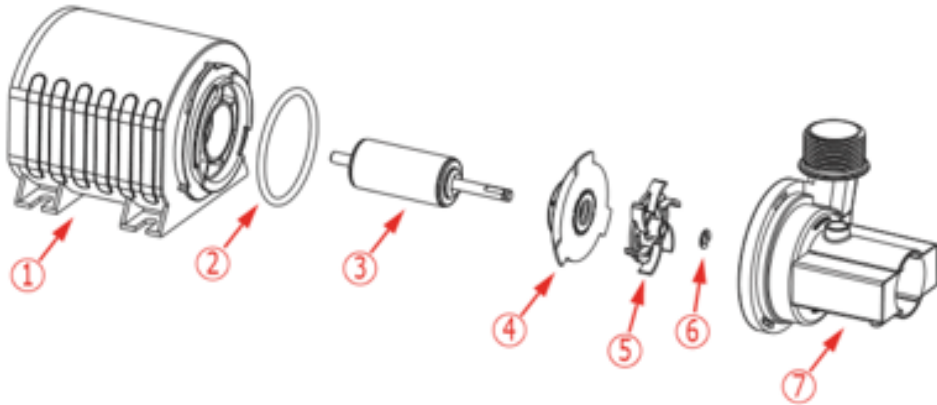

ASSEMBLING

1. Unpack all components carefully. See Figures 1 (unassembled) and 2 (assembled) below.
2. Fit a square tube 75mm x 50mm x 2.5mm x 500mm long (NOT SUPPLIED) to the solar panel hinges TPS50
3. Erect a wood or steel pole next to the trough high enough so when the solar panel is fitted, animals cannot interfere with the solar panel and its parts (photo 1).
4. Adjust the angle of the solar panel to face true north as closely as possible.
5. Place the pump in the trough as per instructions, and fit riser tubes and outlet to the correct height as shown in the instructions (page 6).
6. Run the power cable to the solar panel. The power cable is protected by a metal spiral convoluted tube. This must be securely attached to the pole to ensure minimal interference by animals.
7. Connect the pump power cable to the ON/OFF switch cable and then to the solar panel power cable, taking care with the terminal position. Lock the two power cables in place using the nut on the solar panel power cable. Ensure the pump remains fully submerged in water while the pump is in operation.
8. The solar pump is now ready to operate.

Figures showing TPS50 components and assembly.

Fig 1.



Fig 2.



INSTRUCTIONS

Placement of TPS-50 Pump in Round Troughs.

Round Troughs

Place the pump in the centre of the round trough, making sure that it cannot be reached by livestock. It is recommended that the pump is covered by mesh, or a mesh cage, for protection from the animals being watered.

For best results, the outlet tube should be submerged below the water level between 50mm to 100mm. This should result in a short fountain and wave type motion throughout the round trough. For the larger round troughs, the Y piece can be fitted to the outlet tube between approx. 25mm to 75mm above water level.

Placement of TPS-50 Pump in Round Troughs

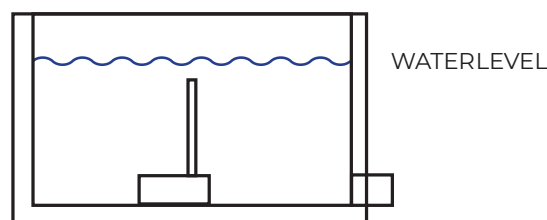
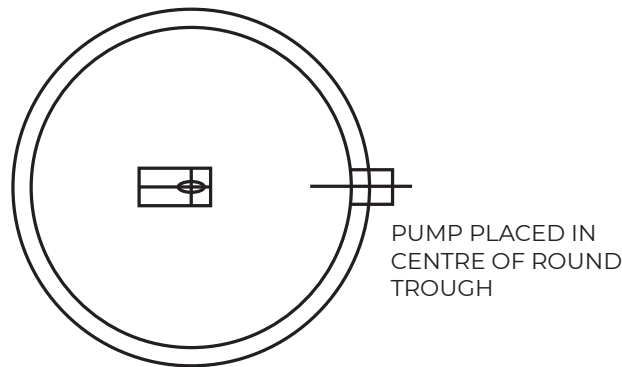

PUMP OUTLET TUBE TO BE 50mm BELOW WATER LEVEL

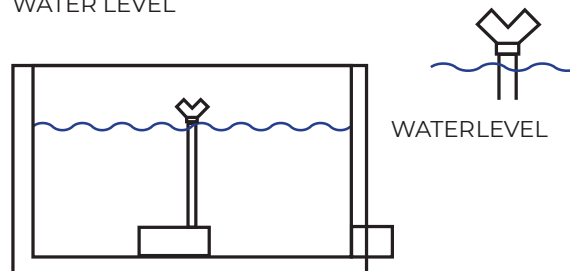

PUMP OUTLET TUBE WITH Y PIECE TO BE 25mm TO 75mm ABOVE WATER LEVEL

Placement of TPS50 Pump in Short Rectangular Troughs up to 2.5 Metres Long

Short Rectangular Troughs up to 2.5 Metres

Place the pump at the float cover end of the trough, ensuring it does not interfere with the float valve operation. The outlet tube and Y or T piece outlet should be approx. 25mm to 75mm above water level. Screw the threaded cap on the threaded outlet of the Y piece to ensure only one outlet of the Y piece is open. Direct the open outlet of the Y piece towards the centre of the trough, so the outlet sprays the water to the end of trough, forming a wave like motion.

Placement of TPS-50 Pump in Short Rectangular Troughs up to 2.5 to 5 Metres Long.

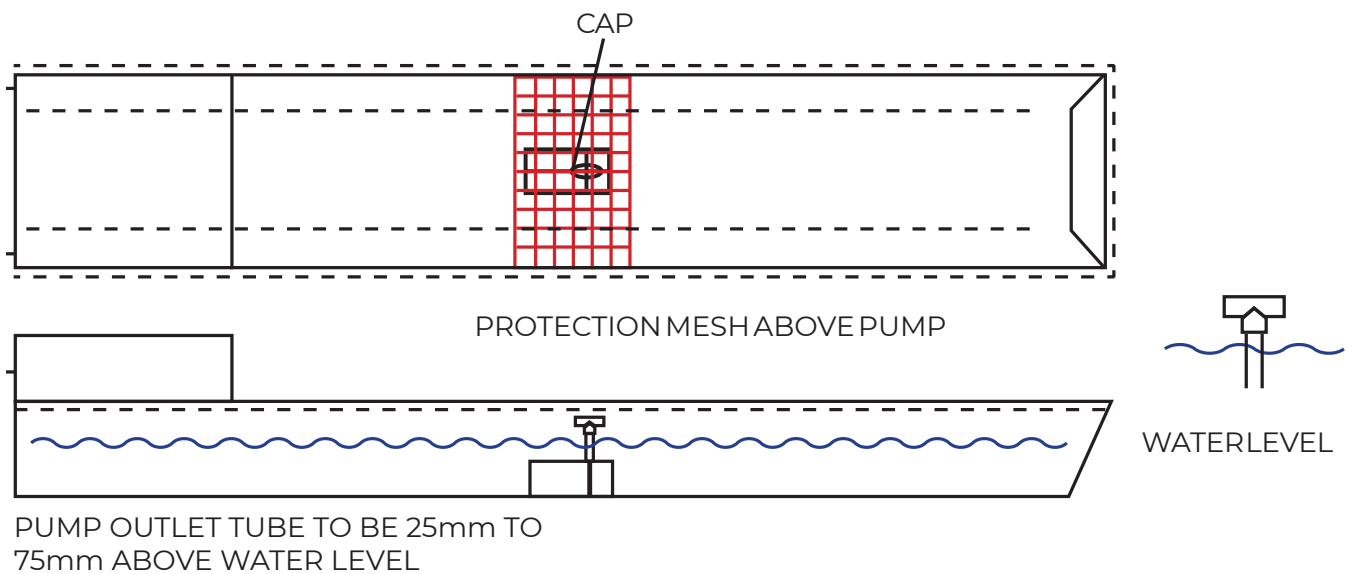

Refer to our website croctroughpumps.com.au for examples of operational pump set ups

PROTECTION

It is critical that the Pump and the Power Cable are protected at all times.

Pump protection

A reinforced mesh cage is recommended, or the use of other suitable means to ensure animals cannot access the pump system.

Example of mesh placed over pump at water level.

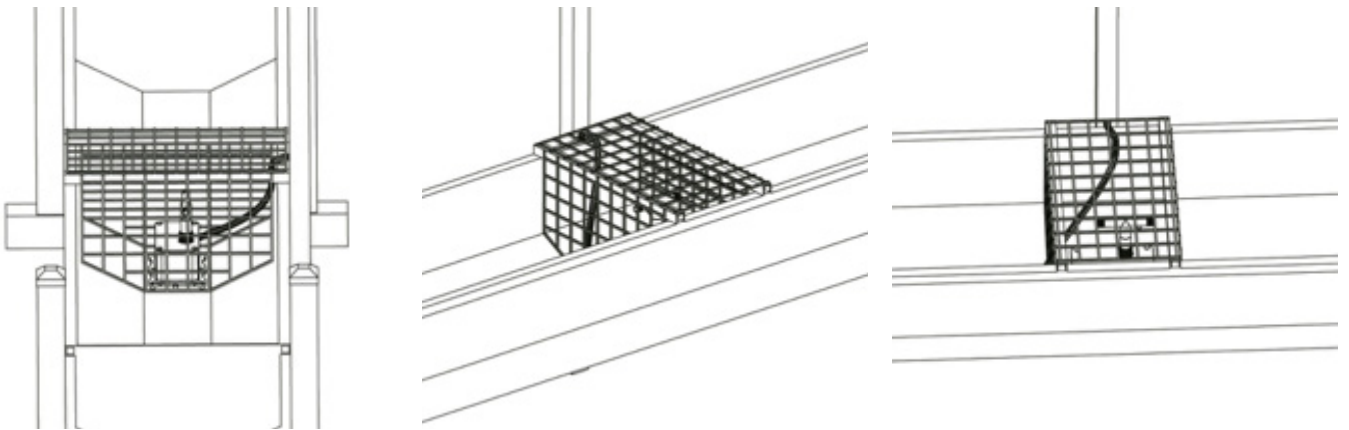

POWER CABLE PROTECTION

The power cable should be completely concealed.

The power cable should be protected inside a metal tube and protected as it enters the trough. Excess cable should be tied or clamped under the solar panel ensuring it is not accessible to the animals (clamps supplied in Kit)

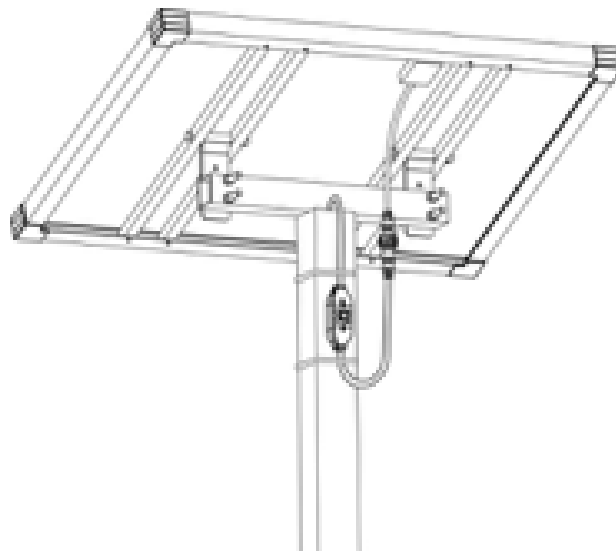

Notes:

- The power cable is protected by metal spiral convoluted tube. This tube must be securely attached to the pole supporting the solar panel, with tube saddles provided. The power cable can also be ran down inside the metal tube to the height of the trough
- The solar panel should be cleaned regularly in all conditions. A damp cloth or window washer/squeegee is recommended.
- Trough standing water level should always be at least 100mm to 150mm below the top edge of the water trough.
- Trough water level should be adjusted if water from the pump is being blown out of the trough by the wind.
- Please refer to the Croc-TPS website for photos of different ways to install the Croc-TPS.
- The solar panel is fitted with a red light to indicate the solar panel is operational, but it does not indicate the amount of power the solar panel is generating.
- The Croc-TPS is not a trough cleaning device. The filter is fitted to protect the pump from becoming blocked and causing damage to the pump.
- The solar panel must be installed on a strong wooden or steel post, out of the reach of the animals being watered, so there is no interference with the solar panel and its parts.
- Pump filter should be cleaned regularly depending on the situation. A coarse laundry brush is recommended.
- The trough should be cleaned thoroughly before installing the pump system.
- If algae is present, it is recommended to treat the trough with an Algaecide to kill the algae cells present in the trough.
- Animals are very inquisitive; they will tamper with and chew on any loose materials when bored. So, it is imperative that pump and cable are secured and protected from all animals.
- The TPS has been trialed in many different trough designs/types. We can only recommend a basic installation and protection method.

Please visit croctroughpumps.com for ideas to assist with your installation.

TROUBLESHOOTING

If the pump does not operate even though the solar panel is in full sunlight, please check the possible failure list below.

PROBLEM	RESOLUTION
No power to the pump	Check the electrical connection between pump and solar module
Water Pump is noisy	Blockage in pump, needs to be cleared
Poor flow	Clean the pump as described in disassembly
No flow	Impeller may be broken, check and replace
Pump not operating but water flowing through tubes	Clean the tube and the filter to ensure they are not blocked

If the pump starts losing power or stops working after operating for a certain time, clean the pump, following the steps below (also see the above figures for demonstration)

Disconnect the pump

1. Pull the filter housing apart from the pump
2. Press on the bottom board while sliding it apart from the pump
3. Turn the impeller cover counter-clockwise to the end and then carefully open the impeller cover
4. Pull the impeller out of the pump
5. Wash every part to clean away the debris
6. Assemble the pump in reverse sequence
7. Connect the pump
8. Clean the solar panel
9. Check the solar panel is not damaged
10. Test power is being produced by the solar panel

Be careful to never drop the ceramic axle when cleaning the pumps; it is very fragile.

DISASSEMBLY INSTRUCTIONS

Pump disassembly and cleaning

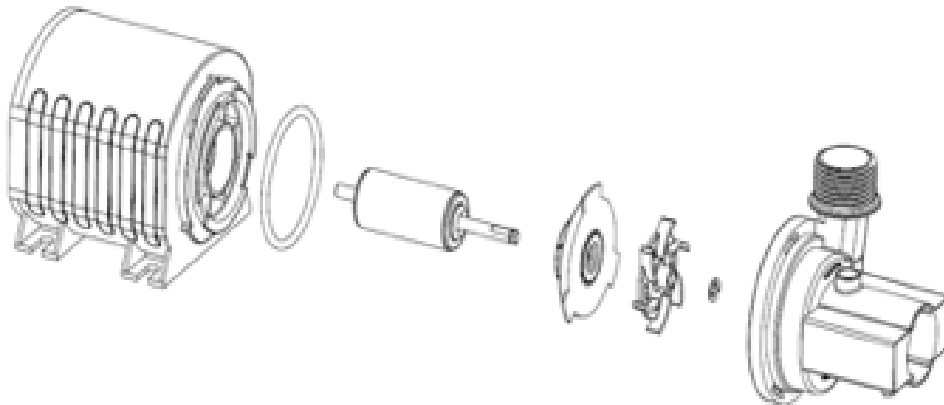

Disassembly Instructions CROC TPS50

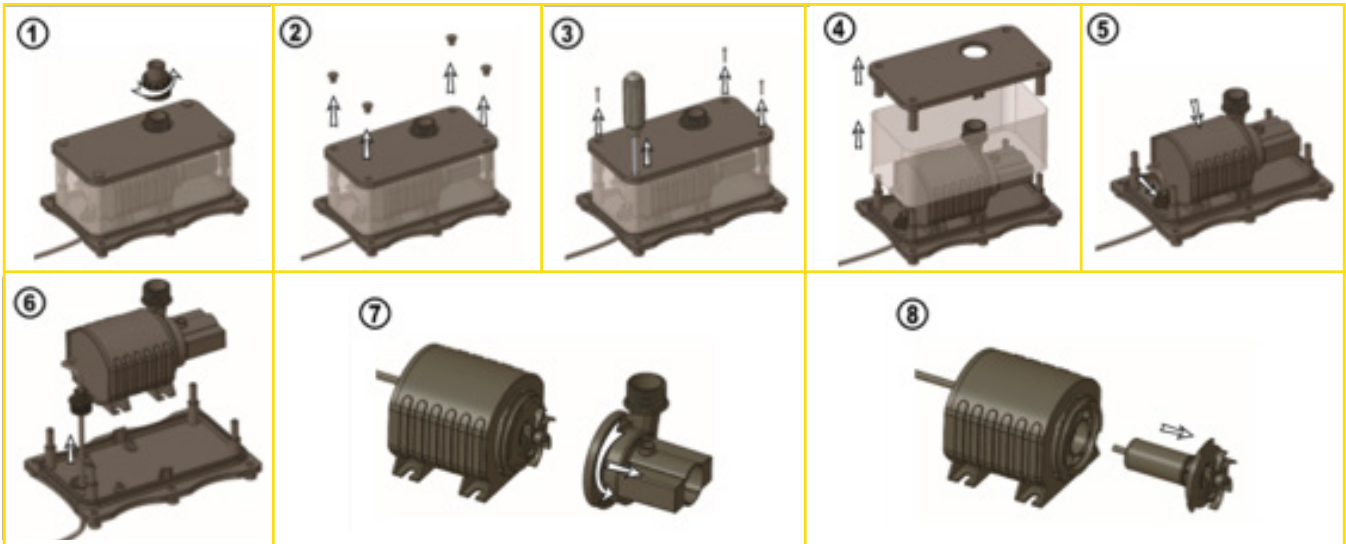

CAUTIONS

- Any altering of the product itself or changing of the components voids the warranty.
- Do not connect the pump to any AC power supply directly; it's designed ONLY for DC power.
- All the connectors are protected against reverse polarity . Do not insert the plug with reverse polarity using unnecessary force.
- Operate the pump in water only (never above 42°C), and especially keep it away from flammable liquids (water maximum salt content 4000ppm). Trials have indicated the pump will operate in higher salt content water, but some failures have occurred due to the harshness of certain water types. Croc-TPS cannot honour the warranty if the pump is regularly run outside of these parameters. Regular servicing and cleaning of the pump is highly recommended.
- Do not strike the solar panel.
- Do not let the pump run dry.

IMPORTANT

DUE TO THE HARSH CONDITIONS, THE WARRANTY IS **VOID** IF USED IN MARINE WATER OR SALTWATER ABOVE 4000 PPM OF SALT.

Trials have indicated the pump will operate in higher salt content water up to 8000ppm of salt, but some failures have occurred due to the harshness of certain water types.

Croc-TPS cannot honour the warranty if the pump is regularly run outside of these parameters. Regular servicing and cleaning of the pump is highly recommended in these circumstances.

This product comes with a 12 months warranty against defects and motor failure (Warranty). The benefits provided in this Warranty are in addition to other rights and remedies available to you under Australian Consumer Law.

The Warranty is provided to the original purchaser of the product on the following terms:

The Warranty is given by;

Grieger Investments Pty Ltd Trading As Croc Trough Pumping Systems

PO Box 3196 Hendra QLD 4011.

Telephone: 0427 166810.

Email: croc-tps@bigpond.com

To make a claim under the Warranty you must return the faulty product to the place of purchase with a valid receipt or proof of purchase.

A Warranty claim must be made within 12 months of the date of purchase.

If your claim complies with the above terms and the product is not an exhaustible item, and no voiding events have occurred, we will (at our sole discretion):

- repair the product, if possible; or
- provide a replacement product; or
- If a replacement product is not available, provide

a refund for the purchase price paid. You will bear the cost associated with claiming under the Warranty, such as the cost of transportation and delivery of the product to and from the place of purchase.

The product contains a complete Impellor Set and O Ring. These items are exhaustible. Exhaustible Items are not covered under the Warranty.

The Warranty will be void if any of the following events occur, as determined by us, at our sole discretion (Voiding Events):

- Any tampering/removal of warranty identification labels of electrical components is evident;
- The defect has arisen due to: an accident, incorrect or inadequate installation, misuse or abuse of the product (including improper maintenance and service), excessive wear and tear, not following manufacturer's guidelines/instructions, or the product has been used in a manner contrary to the purpose or suitability of the product;
- The product has been modified without our authority;
- The defect is caused by power surges/spikes or brownouts.

Loss of livestock, damage to property or personal injury caused by the improper use or abuse of the product will not be covered and the Manufacturer excludes all liabilities for such events, to the extent permitted by Australian law

Additional to the warranty set out above, our goods come with a guarantee that cannot be excluded under the Australian Consumer Law. You are entitled to a replacement or a refund for a major failure and for compensation for any other foreseeable loss or damage. You are also entitled to have goods repaired or replaced or replaced if the goods fail to be of acceptable quality and the failure does not amount to a major failure

Please contact your reseller for original replacement parts.

Patent Pending. The Croc™ Trough Pumping System is the subject of PCT Publication No WO2019056049A1 and associated national and regional phase patent applications.

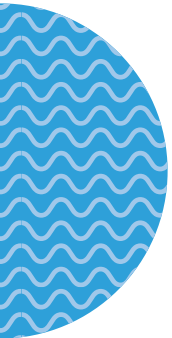
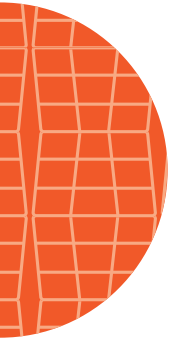
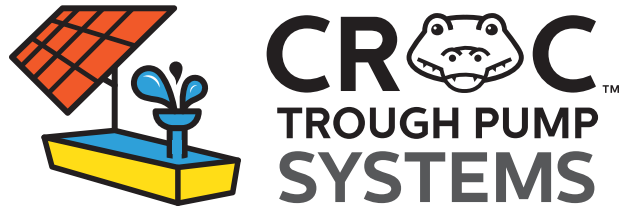

croctroughpumps.com.au